

Outline Dimensions

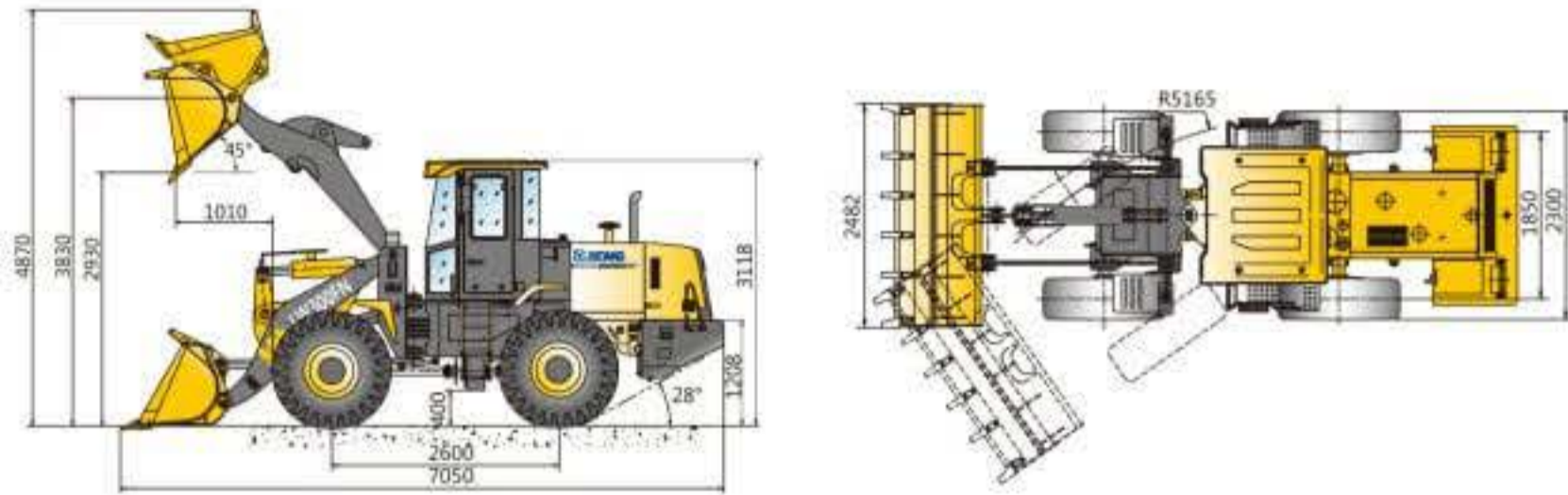

Main Specifications

Description	Specification	Unit	
Rated operating load	3000	kg	
Bucket capacity	1.5~2.5	m ³	
Machine weight	10600±200	kg	
Dump clearance at maximum lift	2770~3260	mm	
Reach at maximum lift	1010~1210	mm	
Wheel base	2600	mm	
Tread	1850	mm	
Height of hinge at maximum lift height	3830	mm	
Working height(fully lifted)	4870	mm	
Max.breakout force	130	kN	
Max.horse power	95	kN	
Hydraulic cycle time-raise	5.5	s	
Total hydraulic cycle time	10	s	
Min. turning radius over tyres	5165	mm	
Articulation angle	35±1	°	
Gradeability	28	°	
Tyre size	17.5-25-12PR		
Overall machine dimension L×W×H	7050×2482×3118	mm	
Model	WP6G125E22		
Emission standards	Emission 2		
Rated Power/Speed	92/2200	kW/rpm	
Fuel Tank	170	L	
Hydraulic Tank	170	L	
Travel speed	I-gear(F/R)	8/10	km/h
	II-gear(F/R)	13/30	km/h
	III-gear(F)	24/-	km/h
	IV-gear(F)	40/-	km/h

Structure and specification are subject to change without notice.In case there is any difference between the description of the machine and the substantial machine,the substantial machine should govern.

LW300FN

WHEEL LOADER



Description

Description	Specification
Rated bucket capacity	1.8m ³
Rated loading capacity	3000kg
Rated power	92kW
Gross weight	10600kg
Dumping height	2930mm
Maximum breakout force	130kN



High efficiency and reliability Inheritance of classic and high maturity and stability

Model Characteristics

- It features high efficiency, energy-saving, and strong power.
- The three-element torque converter and the fixed shaft power shift transmission feature high maturity and reliability.
- The 2600mm wheelbase features high mobility and flexibility and is applicable to all kinds of working sites.
- The bucket is made of high strength material to realize high wear and impact resistance.
- The diversified configurations and complete attachments adapt to the construction needs in different regions and under different working conditions.

The optional A/C and the sound insulation and noise reduction measure build elaborately a comfortable operating environment.

Performance Highlights

- Outstanding capability, with traction at $\geq 9t$ and breakout force at $\geq 13t$.
- High adaptability, with turning radius at 5,165mm (tire center).

Market position

- Industry 3t single-model sales champion.

The warranty period for the front and rear frames, boom, and arm is 2 years or 5,000 hours (whichever comes first), which is far beyond the loader industry warranty level to manifest the top quality of XCMG loaders.



Excellent quality power and drive systems

Strong power

- China-II emission compliance, high performance, and low fuel consumption
- With strong power and high torque reserve factor, this engine meets the instant overload demand during operations and sufficiently provides the power required for heavy-load operations.

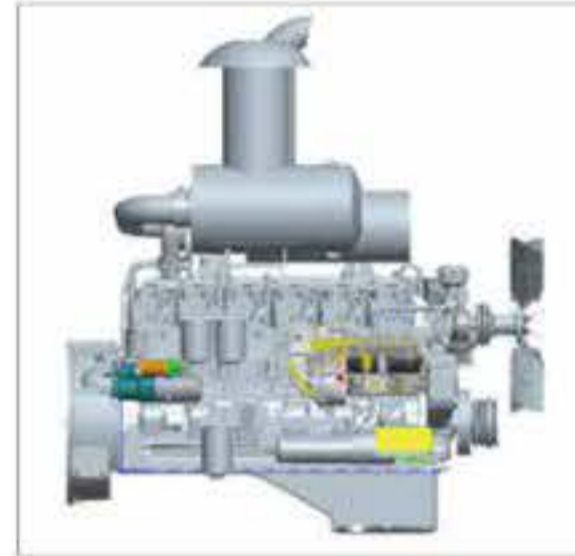

Classic and reliable Transmission and torque converter assembly

- The countershaft power shift transmission features high maturity and reliability.
- The three-element torque converter ensures the maximum utilization of engine power.
- The drive shaft flanges are of international standard specification and the distribution diameter of the fastening bolts is enlarged to realize super-strong torsion resistance and adapt to high strength and heavy-load continuous operations.



Enhanced heavy-duty drive axle of outstanding performances

- All load carrying portions are solid and firm enough to ensure excellent overload resistance and meet the needs of various high strength and high load operations.



Firm and reliable super-strong heavy-duty structural parts.

Super-strong structure

- The finite element analysis technology is applied for structural parts to reduce the stress concentration, eliminate the partial weaknesses, and thoroughly adapt to diversified working conditions.



Optimized bucket shape

- The lengthened bucket bottom and the sharp bucket shape ease the penetration and realize higher bucket loading capacity.
- The contracted flare angle and the reduced cross section ease penetration and lifting.

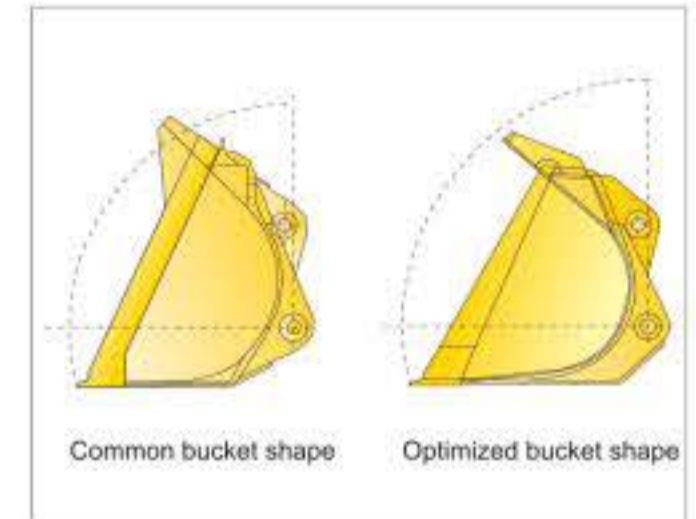

Diversified attachments

- Standard bucket suitable for diversified working conditions.
- Rock bucket: It's dedicated for handling of hard materials (such as rock), featuring good resistance against wear and impact.
- Coal bucket: It's dedicated for handling of bulk materials (such as coal), featuring high bucket capacity and high efficiency.

International quality hydraulic and electric units

- The first-class hydraulic units ensure low pressure loss, less system heating, and high reliability.
- The international quality hydraulic hoses applied feature high heat and pressure resistance and long life.
- The hydraulic pipelines adopt double sealing means (DIN standard 24° taper thread + O-ring) to achieve better sealing performance and effectively solve the leakage problem.
- The harnesses are made of imported quality material and the process layout is optimized to ensure reliable electric circuit system.

